



Introduction new sliding door automation
for escape routes and emergency exit EN16005
with brushless motor

SL5 Emergency

Innovate to simplify

TOTAL CUSTOMER SATISFACTION

Consistent with its innovative vocation addressed to complete customer satisfaction focusing to accept, and also exceed every request and expectation, FACE presents to the market the first series of sliding automation, enlivened by new brushless motors in direct drive of its own design moved from a futuristic electronic control, in replacement of traditional CC motors with switching brushes coupled to a gearbox.

This new generation of automation is also characterized by a series of innovative mechanical solutions, aimed at a remarkable quietness of work and to simplify the installation and maintenance that allow to obtain an important cost reduction.

This breakthrough technology, covered by specific patents, allows to have for all users of FACE automated sliding benefit from a unique set of objective advantages, explained in the following slides.

Extraordinary Energy Saving

Thanks to a **+30%** efficiency of the Brushless motor, **+30%** recovery efficiency gains due to the elimination of the gearbox, **+15%** efficiency of the power supply system into the electronic control achieved by Switch Mode technology, FACE automation allows to obtain the 54 % less electricity consumption in comparison to traditional automations with CC brushes gearmotors and power systems with transformer.

Thanks to these 3 distinctive elements, FACE sliding automations are elected to the role of the first true **“ENERGY SAVING”** automations present in the market.

Reduction of electricity consumption =

- 54%



Longer Life and Reduction Maintenance Costs

Competitors: Double CC Motor or CC Motor with double winding + Gearbox



The History

The main element of usury in a CC motor are brushes, being by definition the Brushless motor without brushes, and also turning low speed, 400 rpm because direct, it's operational life is longer about ten times and the maintenance more than halved and limited to the external parts of the motor.

Having also removed the gearbox, are also delete the maintenance costs due to it's natural wear.

FACE: Only Brushless Motor with double winding



The Future

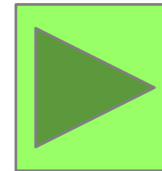

AVANTI

Silence of the Motor

The absence of brushes makes these motors exceptionally quiet, and the elimination of the gearbox enhances more the result, helping to make the automation particularly suitable for environments that require a high level of hush. The unique and patented positioning of the hall sensor inside the engine, it also makes it very compact in its dimensions and functionality.

Competitors: Double CC Motor or CC Motor with double winding + Gearbox

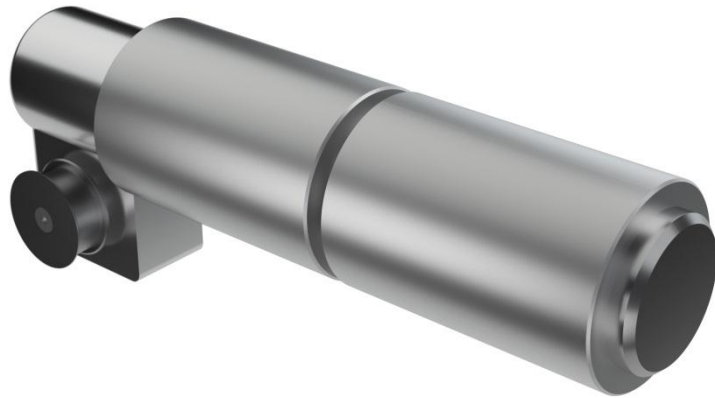

The History

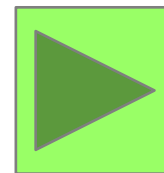

AVANTI

FACE: Only Brushless Motor with double winding



The Future

Elimination of vibrations to the motorized rail

The exclusive motor support system, provides the locking of the support plate in two points interposing between the mounting bushings and the support plate of the rubber dampers that go to eliminate the transmission of vibration to the sliding rail.

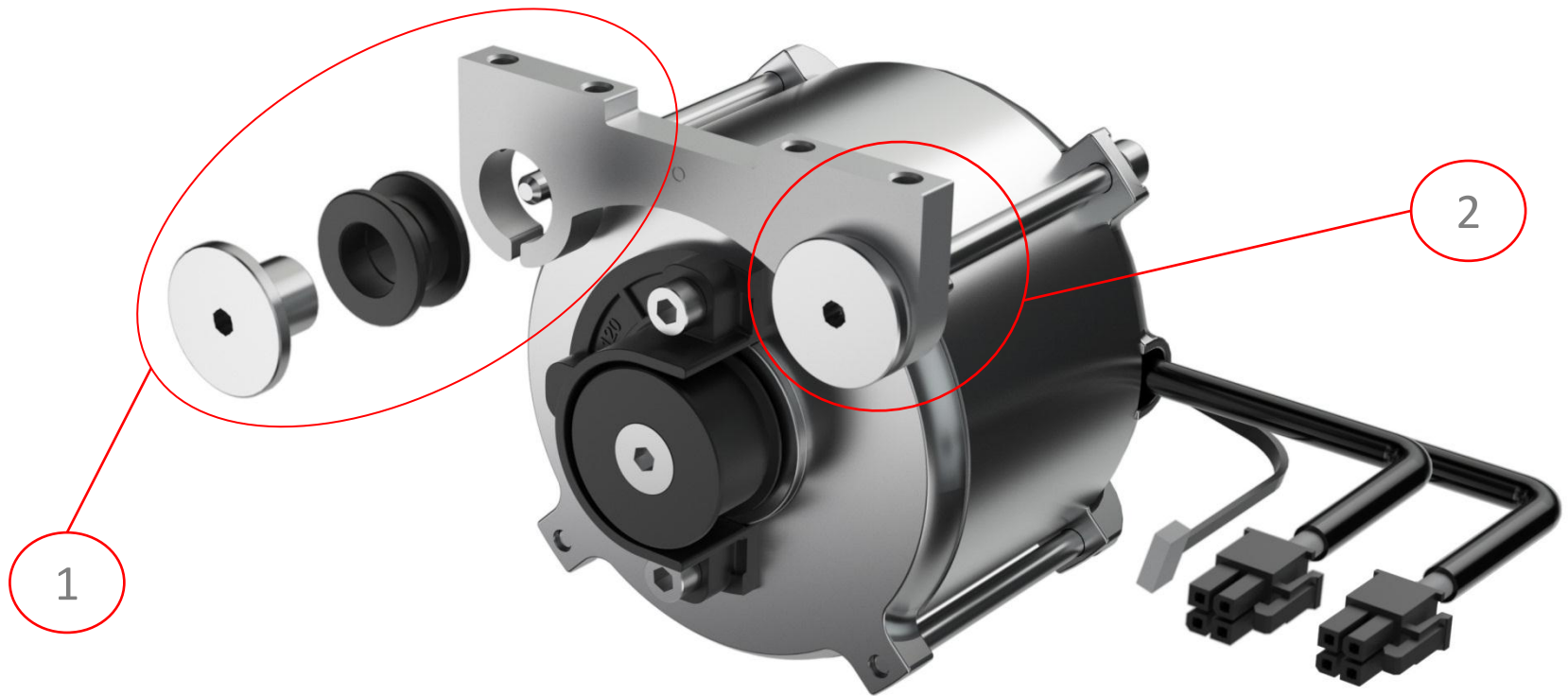

Electronic Control

The advanced electronic system, equipped with a 32 bit microcontrollers, maintains a perfect control over the movement of the motor, enhancing the characteristics, and also allows the perform any adjustment by an alphanumeric display, easily readable even at distance, and can provide diagnostic and detailed information.

The electronic control is already preset in standard mode, you don't need to make any adjustment, your door is already working. However, all parameters are editable, we want to meet your specific needs.

Dedicated terminal are present to each accessory, allowing an easy and simple connection of the control devices and door security, corresponding with the current european standard.



Electronic Control

Emergency functions are supervised by a second 32-bit microcontroller, using an add-on module that doesn't require more space inside the automation, but adapts to the edge of the standard control, providing the necessary connections in a simple and intuitive way. The electronic control, with the motor and the swab kit battery, constitutes a sophisticated emergency system which is always able to recognize damages or even just temporary anomalies such as the absence of the power supply. Guarantees the possibility to evacuate the room by immediate opening of the doors, according to the latest European regulations requirements.



Electronic Control

All the information collected during the operation of the door, and above all control settings, are saved on a micro SD memory easily available, so that you can replicate to similar applications, and reuse when replacing, reducing intervention time. The micro SD card can also be used to upgrade the system, so you always benefit the latest innovations functionality of the door.

The electronic control is provided with standard micro USB for connection to the personal computer, in order to perform more sophisticated diagnostics, update and control.



Electronic Control

The power supply is an extended range 100 - 240 V (50/60 Hz), made with Switch Mode technology, which guarantees highest efficiency and reduces energy consumption of the entire automation. The power supply connection is a standard cable plug, doesn't required installation by specilized personnel.



Elimination of vibrations transmission to structure on which the automation is fixed

FACE is the first that adopted the exclusive 3-stage damping system, by inserting gasket cushioning between the mounting bracket (1) and the motor drive (2), and between the latter and the profile scroll-wheel cart (3), allows to obtain a level of quiet operation than ever before. This is the primary importance for applications in hotels, hospitals, offices, and other similar environments that require a high level of hush, especially at night when the effect of the decrease in ordinary environmental noise a noisy automation becomes an unacceptable nuisance and cause of complaints from guests.

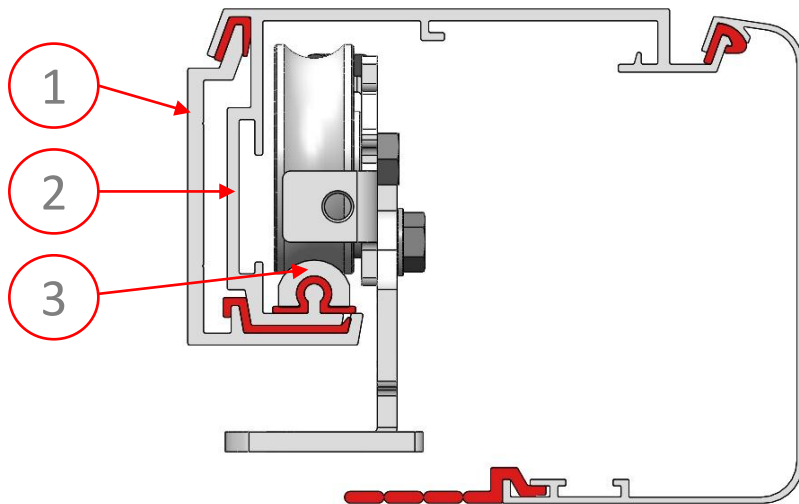

Do Not Disturb



Extraordinary Reduction of Installation Time

The unique and patented fixing system to wall/beam of the support bracket, on which it will be simply hooked the entire length of the motor drive without any additional fixing for drilling/tessellation, enables a single person to install an automation until a 4 m, reducing installation costs by 50%.

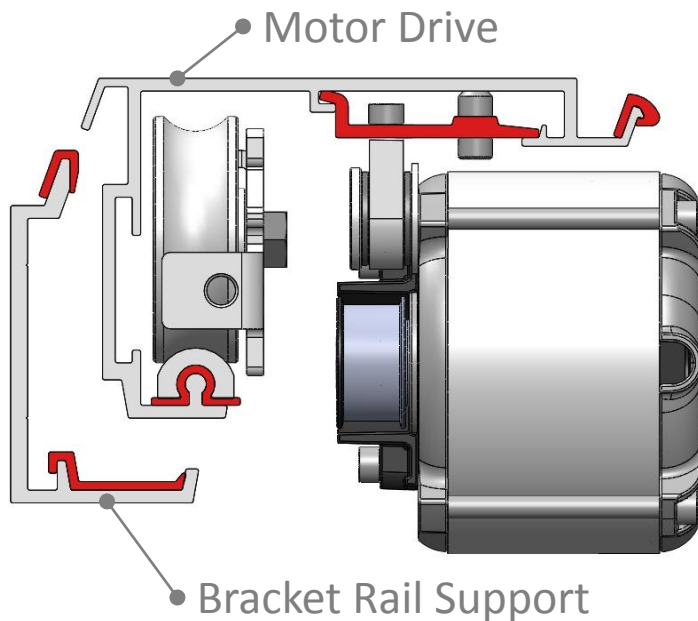

Extraordinary reduction Time for Maintenance

The unique and patented fixing system for snap-front of all internal elements automation, allows a quick and easy replacement, any operation is also facilitated by the fact that in all automation are only used 3 different types of screws that require to have included only one type of key combination, only one type of Allen key T and a single type of screwdriver.

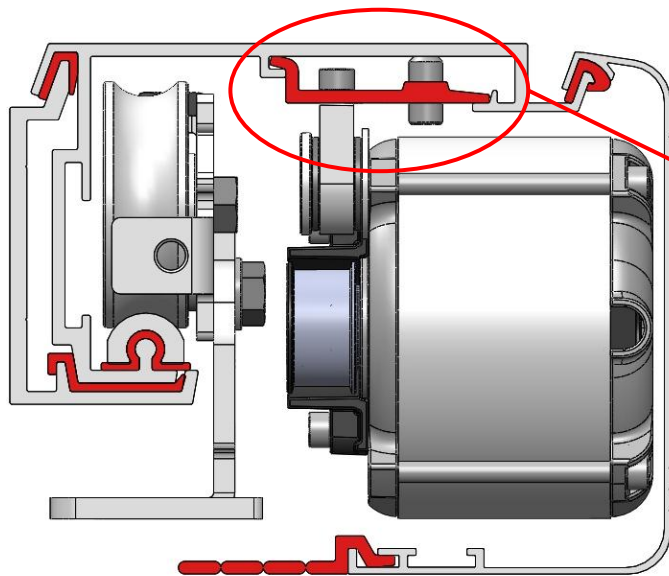

Snap-Front Graft



Esclusive magnetic On-Off Hook support

The unique sensors system support, allows you to remove and put the automation cover (also with magnetic coupling) very rapidly due to the elimination of the mounting and wiring sensors directly onto the cover, reducing access times to automation.

1



2

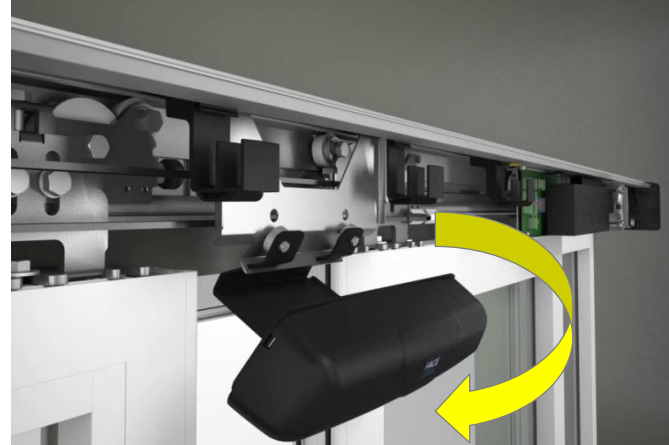

3



4



Designed to be deployed in assembly kit to quickly reach every corner of the world

The SL5A automation was designed to be distributed in assembly kit and with the objective of reducing in a single operation the assembly and installation activity, through a great job of extreme simplification and rationalization of all its parts and systems that bind them together. Except for only the motor and the add-on module to be connected to the electronic control, all other components are exactly the same of the SL5A automation, ensuring maximum rationalization/rotation of its kit warehouse.

The purchase of automation in assembly kit allows 3 more successive different modes of assembly/installation as required:

- 1) You can cut aluminum profiles and assembly automation in your laboratory and then do the final installation on site.
- 2) You can cut the aluminum profiles in your laboratory and assembly and install automation in a single operation performed directly on site.
- 3) You can cut the aluminum profiles in your laboratory , on-site install only what you need to "close" the environment, and at a later time to complete the assembly of automation with its parts and accessories more high-tech and expensive.

However will be possible to buy automations assembled at measure.